



1685 West Higgins Road, Hoffman Estates, Illinois 60169
heparks.org t (847) 885-7500 f (847) 885-7523



March 3, 2017

Tracey Crawford
Executive Director
Northwest Special Recreation Association
3000 Central Rd, Ste 205
Rolling Meadows, IL 60008

RE: Improvements proposed to be financed using special recreation levy

Dear Ms. Crawford:

The Hoffman Estates Park District hereby notifies and requests approval of the NWSRA Board of Directors for the proposed expenditure of funds from the District's special recreation levy to pay the cost of the following improvements:

- Colony Park Playground for ages 2-12 yrs. Replace existing playground equipment with accessible equipment. Remove existing ADA loose fill fiber no longer in compliance and reinstall new drainage and ADA compliant loose fill fiber mulch fall surface. Install ADA concrete ramp to playground equipment. Install wheel chair accessible sand digger.
\$12,641
- Victoria Park Playground 2-5yrs & 5-12yrs & Swings. Replace existing playground equipment with transfer deck and accessible equipment. Remove existing ADA loose fill fiber no longer in compliance and reinstall new drainage and ADA compliant loose fill fiber mulch. Remove and replace concrete walk areas that are not in conformance to ADA standards.
\$37,277
- Seascape Water Playground 2-12yrs. Replace existing playground equipment with ground level accessible play equipment. Remove part of the existing sand surface and install poured in place rubber surface to facilitate access to the new water play equipment. Remove and replace concrete walk areas that are not in conformance to ADA standards.
\$21,119

- Victoria Park pathway reconstruction. Remove existing asphalt and concrete surfaces and re-grade subgrade so as to conform to less than the maximum running and cross slope requirement of ADA. Construct dry block retaining wall at utility pedestals impacted by new grade elevations. Re-pave surface with asphalt. 5/8 of the 8-foot wide path width to be reimbursed as part of this request.

\$17,380

- Evergreen Park Pathway renovation. Remove existing asphalt surface and re-grade subgrade so as to conform to less than the maximum running and cross slope requirement of ADA. Re-pave surface with asphalt. 5/8 of the 8-foot wide path width to be reimbursed as part of this request.

\$38,955

- Westbury Park Pathway reconstruction. Remove existing asphalt surface that has settled and/ or heaved over time due to pour underlying soils. Re-grade subgrade so as to conform to less than the maximum running and cross slope requirement of ADA. Re-pave surface with asphalt. 5/8 of the 8-foot wide path width to be reimbursed as part of this request.

\$7,544

The total estimated cost of the improvements is \$315,954 of which the district is asking to charge the Special Recreation Fund up to **\$134,916**. The improvements are expected to be substantially complete by August 1, 2017.

Anticipated benefits of the projects to NWSRA are as follows:

- Installation of ADA accessible playground equipment, fall surface and correction of existing slopes in playgrounds and parks to allow for greater participation on the equipment at these facilities, and
- Pathway improvements will provide access into and around the park venues.

The Hoffman Estates Park District respectfully requests that you review this request and present it with your approving recommendation to the NWSRA Board of Directors. If you have any questions or require additional information, please do not hesitate to contact me.

Sincerely,



Dean R. Bostrom
Executive Director

2017 NWSRA project cost breakdown based on bids awarded

3/1/2017

Colony 2-12 year old playground replacement

	Total	Capital fund	NWSRA	NWSRA %
Colony 2-12 composite play structure purchase	16,335	14,317	2,018	12%
Sand Digger	996	996	0	0
ADA sand digger	882	0	882	100%
Security fence & Demo	5,370	5,370	0	0
Concrete ramp into fall surface	525	0	525	100%
Playground install	6,739	5,930	809	12%
Drainage for fall surface	660		660	100%
Woodfiber fall surface	7,848	0	7,748	100%
Sand replacement for diggers	340	340	0	0%
Landscape restoration	5,600	5,600	0	0%
TOTAL	45,294	32,553	12,641	28%

Victoria Park playground replacement & path wall

Victoria 2-5 composite playstructure purchase	5,988	5,269	719	12%
Victorias 5-12 composite playstructure purchase	41,449	36,475	4,974	12%
Bucket spinner purchase	967	0	967	100%
Swing purchase	3,584	3,584	0	0%
Security fence & Demo	10,361	10,361	0	0%
Dry Blockwall to acomidate ramp fill at utility boxes	6,720	0	6,720	100%
Concrete replacement due to vertical rise and gap issues	1,430	0	1,430	100%
Playground install	16,089	14,158	1,931	12%
Drainage for fall surface	6,700	0	6,700	100%
Woodfiber fall surface	13,837	0	13,837	100%
Landscape restoration	3,540	3,540	0	0%
	110,665	73,388	37,277	29% for playground only

Seascape Water play area renovation

Purchase playground equipment (Total ground accessible)	17,331	15,251	2,079	12%
Security and demo	12,970	12,970	0	0
Concrete replacement due to vertical rise and gap issues	4,770	0	4,770	100%
Playground install	10,715	1,285	0	0
Drainage for fall surface	5,520	0	5,520	100%
Sand replacement	1,766	1,766	0	0
Rubber fall surface	8,750	0	8,750	100%
	61,821.30	31,272	21,119	34%

Victoria Asphalt Path

Cut and fill path profile and pave with asphalt	17,057	6,397	10,660	0.625%
Dry Blockwall to accomidate ramp fill at utility boxes	6,720	0	6,720	100%
	23,777	6,397	17,380	

Evergreen Path Re-grade & repave

	62,328	23,373	38,955	0.625%
--	--------	--------	--------	--------

Westbury Path Re-grade & repave

	12,069	4,525	7,544	0.625%
--	--------	-------	-------	--------

Asphalt Bid Results

2/22/17	Chicagoland Paving Contractors, Inc. 225 Telser Rd, Lake Zurich, IL 60047 847-550-9687 chicagoland1@sbcglobe.com	Schroeder Asphalt Services, Inc. PO Box 831, Huntley, IL 60142 815-923-4380 kyle@schroederasphalt.com	Evans & Son Blacktop, Inc 3N775 Powis Rd, W Chicago, IL 60185 630-377-1212 howard@blacktop.biz	Maneval Construction 38090 W. Conc Dr, Inslesio, IL 600041 847-548-2244 elitchfield@manevalconstruction.com	Allstar Asphalt, Inc 165 W. Hintz Rd, Wheeling, IL 60090 847-419-1200 sales@allstarasphaltinc.com	
Bond	X	X	X	X	X	
#1 EVERGREEN						
Ever 1-1	\$9,450.00	\$16,065.00	\$8,862.00	\$11,865.00	\$9,450.00	
Ever 1-2	\$47,250.00	\$43,575.00	\$41,769.00	\$48,562.50	\$21,945.00	
Ever 1-3	\$21,000.00	\$25,200.00	\$11,697.00	\$25,620.00	\$31,500.00	
#1 TOTAL	\$77,700.00	\$84,840.00	\$62,328.00	\$86,047.50	\$62,895.00	
#2 HASSELL MAINT						
Sq. yd	\$10.50	\$16.00	\$13.72	\$19.00	\$18.00	
Add' Work	29/sq yd	16.55/sq yd	16.11/sq yd	25/sq yd	27/sq yd	
#2 TOTAL	\$19,950.00	\$30,400.00	\$26,068.00	\$36,100.00	\$34,200.00	
#3 WESTBURY						
Wes D1	\$5,200.00	\$3,800.00	\$2,680.00	\$3,600.00	\$10,000.00	
Wes P1	\$287.50	\$345.00	\$297.00	\$747.50	\$230.00	
Wes P2	\$5,200.00	\$4,550.00	\$2,115.00	\$3,900.00	\$1,300.00	
Wes P3	\$1,750.00	\$2,520.00	\$2,533.00	\$2,700.00	\$1,100.00	
Wes P4	\$1,000.00	\$1,000.00	\$1,181.00	\$1,400.00	\$600.00	
Wes P5	\$150.00	\$100.00	\$82.00	\$500.00	\$500.00	
Wes P6	\$2,000.00	\$4,000.00	\$1,840.00	\$3,000.00	\$3,000.00	
Wes P7	\$1,200.00	\$2,400.00	\$1,341.00	\$2,100.00	\$1,500.00	
TOTAL WESTBURY	\$16,787.50	\$18,715.00	\$12,069.00	\$17,947.50	\$18,230.00	
#4 VICTORIA						
VP1	\$5,729.00	\$8,850.00	\$7,101.00	\$700.00	\$10,750.00	
VP2	\$561.00	\$374.00	\$307.00	\$1,122.00	\$374.00	
VP3	\$5,610.00	\$14,960.00	\$9,649.00	\$11,220.00	\$6,732.00	
TOTAL VICTORIA	\$11,900.00	\$24,184.00	\$17,057.00	\$13,042.00	\$17,856.00	
\$7,500.00						
TOTAL W/ALLOW	\$133,837.50	\$165,639.00	\$125,022.00	\$160,637.00	\$140,681.00	

Asphalt Bid Results

2/22/17		Advance Paving Solutions, Inc. 19148 104th Ave, Mokena, IL 60448 dleisen@advantagepavinginc.com				
Bond	X	X				
#1 EVERGREEN						
Ever 1-1	\$8,400.00	\$5,985.00				
Ever 1-2	\$40,950.00	\$41,212.50				
Ever 1-3	\$21,000.00	\$27,615.00				
#1 TOTAL	\$70,350.00	\$74,812.50				
#2 HASSELL MAINT						
Sq. yd	\$4.00	\$13.85				
Add' Work	28/sq yd	22.50/sq yd				
#2 TOTAL	\$7,600.00	\$26,315.00				
#3 WESTBURY						
Wes D1	\$26,000.00	\$5,200.00				
Wes P1	\$386.40	\$460.00				
Wes P2	\$5,850.00	\$4,290.00				
Wes P3	\$4,545.00	\$1,800.00				
Wes P4	\$1,000.00	\$700.00				
Wes P5	\$351.00	\$500.00				
Wes P6	\$1,950.00	\$2,650.00				
Wes P7	\$2,700.00	\$945.00				
TOTAL WESTBURY	\$42,782.40	\$16,545.00				
#4 VICTORIA						
VP1	\$19,200.00	\$6,900.00				
VP2	\$374.00	\$935.00				
VP3	\$29,920.00	\$7,106.00				
TOTAL VICTORIA	\$49,494.00	\$14,941.00				
\$7,500.00						
TOTAL W/ALLOW	\$177,726.40	\$140,113.50				

Install PG Victoria, Colony Seascape; Concrete Victoria, Colony, Maint, Evergreen;
 Landscape Victoria, Colony, Evergreen, Westbury - February 22, 2017

	Innovation Landscape, Inc. PO Box 505 Plainfield, IL 60544 815-557-0473 nataly@innovationlandscapeinc.com	George's Landscaping 1410 Mills Rd, Joliet, IL 60433 815-774-0350 george@georgeslandscaping.com	Hacienda Landscaping, Inc. 2005 Cumberland Dr, Plainfield, IL 60586 hacienda5779@yahoo.com	R. A. Mancini, Inc 481 Scotland Rd, Unit 101, Lakemoor, IL 60051 815-344-0600 andy@ramancini.com	Elanar Construction, 6620 W. Belmont Ave, Chicago, IL 60634 773762877011 ross@elanar.com
BOND	X	X	X	x	x
VICTORIA					
Site Security	\$2,800.00	\$2,450.00	\$2,100.00	included in Demo	\$1,925.00
Demo	\$10,361.00	\$10,216.00	\$11,152.00	\$19,289.50	\$12,070.00
Dry Block	\$6,720.00	\$5,110.00	\$8,400.00	included in Install	\$6,440.00
Concrete	\$1,430.00	\$2,409.00	\$1,540.00	included in Install	\$2,310.00
PG&Bollard Install	\$16,089.44	\$19,055.00	\$15,800.00	\$20,600.00	\$19,520.00
Drain	\$6,700.00	\$4,513.00	\$8,610.00	\$15,532.00	\$4,998.00
Wood Fall Surface	\$13,837.50	\$14,800.00	\$11,250.00	\$15,025.00	\$13,795.00
Landscape	\$3,540.00	\$4,140.00	\$7,020.00	\$4,790.00	\$7,565.00
TOTAL VICTORIA	\$61,477.94	\$62,693.00	\$65,872.00	\$75,236.50	\$68,623.00
COLONY					
Security & Demo	\$5,370.00	\$5,050.25	\$4,559.00	\$9,041.00	\$5,470.00
Concrete	\$525.00	\$971.25	\$315.00	\$455.00	\$1,050.00
PG Install	\$6,738.80	\$7,796.00	\$6,000.00	\$4,200.00	\$6,800.00
Drain	\$660.00	\$715.00	\$560.00	\$2,550.00	\$750.00
Wood Fall Surface	\$7,847.50	\$7,900.00	\$6,150.00	\$8,150.00	\$7,900.00
Sand Replacement	\$340.00	\$260.00	\$360.00	\$398.00	\$500.00
Landscape Restore	\$5,600.00	\$8,022.50	\$12,900.00	\$10,375.00	\$11,720.00
TOTAL COLONY	\$27,081.30	\$30,715.00	\$30,844.00	\$35,169.00	\$34,190.00
Seascape (FAC)					
Security	Included in Demo	\$7,350.00	\$2,350.00	\$5,000.00	included in demo
Demo	\$12,970.00	\$5,789.00	\$4,450.00	\$14,950.00	\$10,800.00
Concrete	\$4,770.00	\$8,612.50	\$4,770.00	\$5,035.00	\$6,095.00

Install PG Victoria, Colony Seascape; Concrete Victoria, Colony, Maint, Evergreen;
 Landscape Victoria, Colony, Evergreen, Westbury - February 22, 2017

PG Install	\$10,715.38	\$8,950.00	\$7,000.00	\$5,500.00	\$8,450.00
Drain	\$5,520.00	\$4,247.50	\$4,040.00	\$7,655.00	\$5,240.00
Sand play	\$1,765.80	\$1,100.00	\$1,240.00	\$2,110.00	\$2,240.00
Rubber Surface	\$8,750.00	\$11,637.00	\$15,750.00	\$16,187.50	\$9,100.00
TOTAL SEASCAPE	\$44,491.18	\$47,686.00	\$39,600.00	\$51,437.50	\$41,925.00
MAINTENANCE					
Concrete	\$3,500.00	\$4,850.00	\$1,400.00	\$1,800.00	\$1,850.00
TOTAL MAINTENANCE	\$3,500.00	\$4,850.00	\$1,400.00	\$1,800.00	\$1,850.00
EVERGREEN					
Concrete	\$9,600.00	\$10,360.00	\$11,200.00	\$7,800.00	\$8,400.00
Landscape	\$10,800.00	\$13,560.00	\$20,400.00	\$14,500.00	\$15,780.00
TOTAL EVERGREEN	\$20,400.00	\$23,920.00	\$31,600.00	\$22,300.00	\$24,180.00
WESTBURY PATH					
Landscape	\$2,200.00	\$2,480.00	\$3,300.00	\$2,500.00	\$3,520.00
TOTAL WESTBURY	\$2,200.00	\$2,480.00	\$3,300.00	\$2,500.00	\$3,520.00
TOTAL BID + \$7,500 ALLOWANCE	\$166,650.42	\$179,845.00	\$180,116.00	\$195,943.00	\$181,788.00



HOFFMAN ESTATES PARK DISTRICT
 REMIT INVOICE TO:
 1685 WEST HIGGINS ROAD
 HOFFMAN ESTATES, IL 60169
 ACCOUNTSPAYABLE@HEPARKS.ORG
 (847) 885-7500

" SEA SCAPE WATER PLAYGROUND"
PURCHASE ORDER

P.O. NO.	REQ. NO.	ORDER DATE	VEND NO.
20175930	91706042	02/28/2017	KOM930
ORDERED BY	DEPARTMENT	CONTRACT	
gbuczkowski	BUS		

VENDOR ADDRESS:
 KOMPAN INC
 930 BROADWAY

TACOMA, WA 98402
 (888) 579-8223

SHIP TO:
 PARKS SERVICE MAINTENANCE
 2352 HASSELL ROAD

HOFFMAN ESTATES, IL 60169

PO DESCRIPTION: WATER PLAYGROUND EQUIPMENT SAND AREA SEASCAPE

QUANTITY	UNITS	DESCRIPTION	UNIT PRICE	AMOUNT
1	EACH	MERMAIDS FOUNTAIN 60CMM INGROUND 12-97-2300-5000 SEA SAND PLAY AREA RPLC 7,276.00	7,276.00	7,276.00
1	EACH	WATERFALL & CHAIN IN GROUND 12-97-2300-5000 SEA SAND PLAY AREA RPLC 9,562.50	9,562.50	9,562.50
1	EACH	FREIGHT 12-97-2300-5000 SEA SAND PLAY AREA RPLC 492.00	492.00	492.00
TAX EXEMPT ID: 362546738			NET TOTAL:	17,330.50

Craig Talsma, Deputy Director

Dean Bostrom, Executive Director

03/01/2017
 DATE

DO NOT ACCEPT THIS ORDER UNLESS IT IS SIGNED.

1. Mail invoices to: Attention Accounts Payable - 1685 W. Higgins Rd. Hoffman Estates, IL 60169.
2. All packages, cartons, or other containers must be plainly marked with the purchase order numbers.
3. Whenever a delivery is rejected, the vendor shall be notified and be given the reason for the rejection. All rejected deliveries shall be held at the vendor's risk and he shall bear the expense of removal.
4. The Hoffman Estates Park District is specifically exempt from payment of Federal Excise Tax, and State Sales and Use Tax. Where exemption certificates are necessary to relieve vendor or manufacturer of tax liability, the exemption certificate shall be furnished to Hoffman Estates Park District with invoice.

SPECIAL NOTES:

This contract calls for the construction of a "public work," within the meaning of the Illinois Prevailing Wage Act, 820 ILCS 130.01 et seq. ("The Act"). The Act requires contractors and subcontractors to pay laborers, workers and mechanics performing services on public works projects no less than the "prevailing rate of wages" (hourly cash wages plus fringe benefits) in the county where the work is performed. For information regarding current prevailing wage rates, please refer to the Illinois Department of Labor's website at: <http://www.state.il.us/agency/idol/rates/rates.HTM>. All contractors and subcontractors rendering services under this contract must comply with all requirements of the Act, including but not limited to, all wage, notice and record keeping duties.

SEASCAPE WATER PLAYGROUND

KOMPAN Product Info

MERMAID'S FOUNTAIN - M590P



Best User Age: 2-5 years

Footings: In-ground posts
Surface installation also available

Technical information available at koman.com

ADA ANALYSIS

Elevated Activities: 0	Accessible Elevated Activities	Accessible Ground Level Activities	Accessible Ground Level Play Types
Present	0	1	1
Required	0	1	1

MOMENTS

Plumbing: Available with hose quick connect or permanent plumbing.

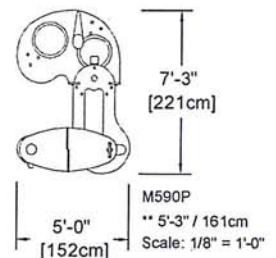

To verify product certification, visit www.ipema.org

* = Highest designated play surface.
** = Total height of product.

Highest designated play surface and space required are according to ASTM F1487.

Equipment must be installed over resilient surfacing appropriate to the safety guidelines in your area.

Product development is an ongoing process. We reserve the right to make modifications on all our products. This product may not be mirrored, scaled or altered in any way. Safety zones must be retained for proper placement of equipment. If any changes are required, please contact your KOMPAN representative at 1.800.426.9788.

SEASCAPE WATER PLAYGROUND

KOMPAN Product Info

WATERFALL - M591P



Best User Age: 2-5 years

Footings: In-ground posts
Surface installation also available

Technical information available at kompan.com

ADA ANALYSIS	Elevated Activities: 0	Accessible Elevated Activities	Accessible Ground Level Activities	Accessible Ground Level Play Types
	Present	0	1	1
	Required	0	1	1

MOMENTS

Plumbing: Available with hose quick connect or permanent plumbing.

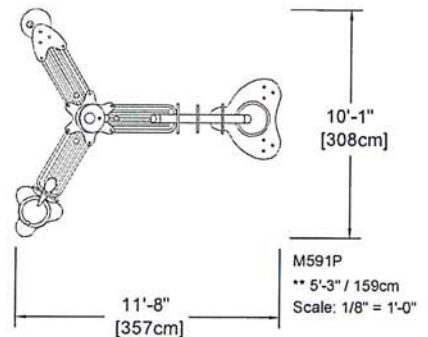
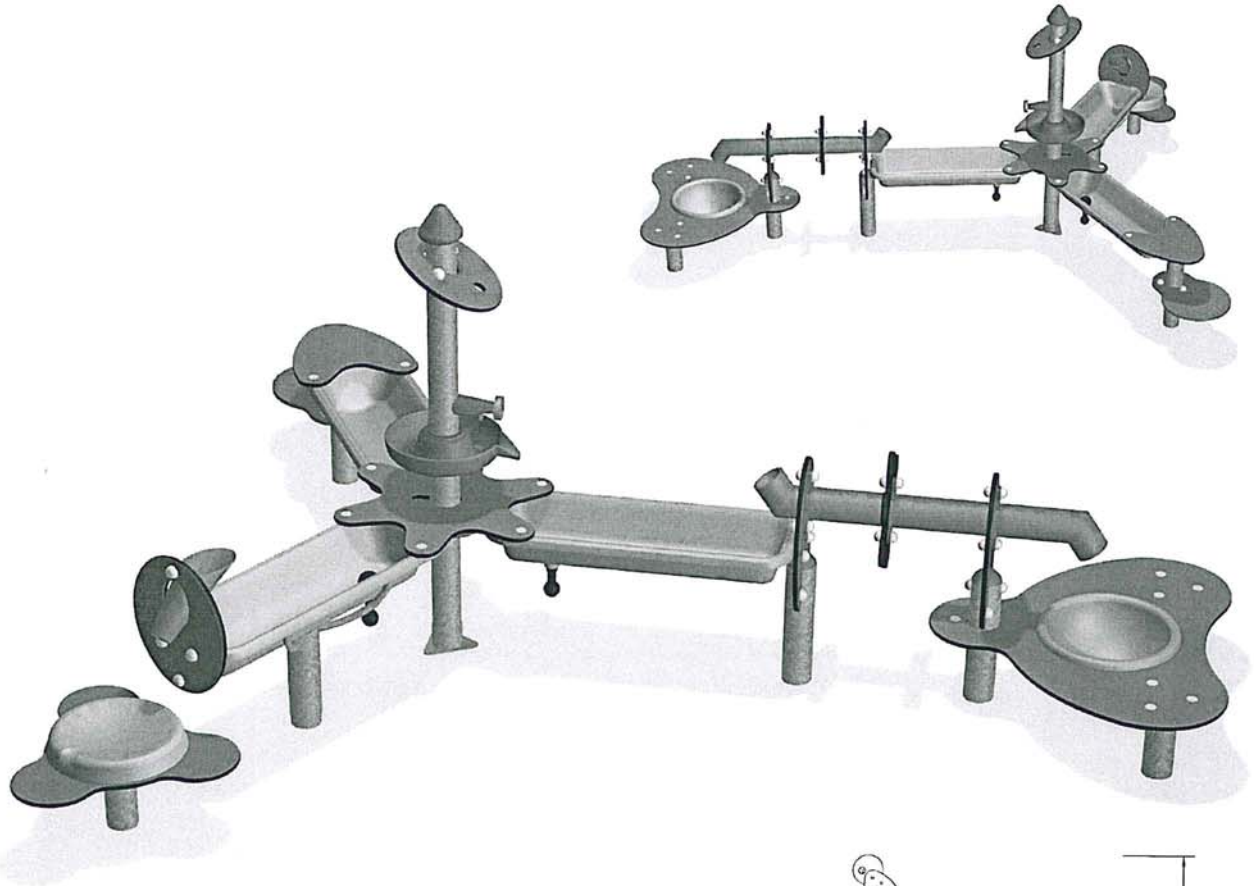

To verify product certification, visit www.ipema.org

* = Highest designated play surface.
** = Total height of product.

Highest designated play surface and space required are according to ASTM F1487.

Equipment must be installed over resilient surfacing appropriate to the safety guidelines in your area.

Product development is an ongoing process. We reserve the right to make modifications on all our products. This product may not be mirrored, scaled or altered in any way. Safety zones must be retained for proper placement of equipment. If any changes are required, please contact your KOMPAN representative at 1.800.426.9788.



HOFFMAN ESTATES PARK DISTRICT
 REMIT INVOICE TO:
 1685 WEST HIGGINS ROAD
 HOFFMAN ESTATES, IL 60169
 ACCOUNTSPAYABLE@HEPARKS.ORG
 (847) 885-7500

VICTORIA & COLONY PLAYGROUNDS

PURCHASE ORDER

P.O. NO.	REQ. NO.	ORDER DATE	VEND NO.
20175929	91706040	02/28/2017	ZEN400
ORDERED BY	DEPARTMENT	CONTRACT	
gbuczowski	BUS		

VENDOR ADDRESS:
 ZENON COMPANY
 400 W DUNDEE ROAD
 SUITE 110
 BUFFALO GROVE, IL 60089-3415
 847-215-6050

SHIP TO:
 PARKS SERVICE MAINTENANCE
 2352 HASSELL ROAD

 HOFFMAN ESTATES, IL 60169

PO DESCRIPTION: SUPPLY AND DELIVER PLAYGROUND EQUIPMENT PER BID & BOARD AWARD

QUANTITY	UNITS	DESCRIPTION	UNIT PRICE	AMOUNT
1	EACH	MODULAR PLAY STRUCTURE VICTORIA RETRO 12-97-0600-5000 VICTORIA S PLYGRND RPLC 26,496.00	26,496.00	26,496.00
1	EACH	MODULAR PLAYSTRUCTURE VICTORIA RETRO 09-97-0600-5000 VICTORIA S PLYGRND RPLC 13,668.00	13,668.00	13,668.00
1	EACH	MODULAR PLAYSTRUCTURE COLONY FESTIVE 12-97-0500-5000 COLONY PLYGRND 2-5YR RPLC 14,317.00	14,317.00	14,317.00
1	EACH	MODULAR PLAYSTRUCTURE COLONY FESTIVE 09-97-0500-5000 COLONY PLYGRND 2-5YR RPLC 2,018.00	2,018.00	2,018.00
1	EACH	SAND DIGGER 12-97-0500-5000 COLONY PLYGRND 2-5YR RPLC 996.00	996.00	996.00
1	EACH	SAND DIGGER ADA 09-97-0500-5000 COLONY PLYGRND 2-5YR RPLC 882.00	882.00	882.00
TAX EXEMPT ID: 362546738			NET TOTAL:	58,377.00

Craig Talsma, Deputy Director

Dean Bostrom, Executive Director

03/01/2017
 DATE

DO NOT ACCEPT THIS ORDER UNLESS IT IS SIGNED.

1. Mail invoices to: Attention Accounts Payable - 1685 W. Higgins Rd. Hoffman Estates, IL 60169.
2. All packages, cartons, or other containers must be plainly marked with the purchase order numbers.
3. Whenever a delivery is rejected, the vendor shall be notified and be given the reason for the rejection. All rejected deliveries shall be held at the vendor's risk and he shall bear the expense of removal.
4. The Hoffman Estates Park District is specifically exempt from payment of Federal Excise Tax, and State Sales and Use Tax. Where exemption certificates are necessary to relieve vendor or manufacturer of tax liability, the exemption certificate shall be furnished to Hoffman Estates Park District with invoice.

SPECIAL NOTES: PER LOW BID AND BOARD AWARD. CALL BILL FALSETTI 24HRS PRIOR TO DELIVERY 847-561-1327

VICTORIA PARK SOUTH TOP VIEW

ADA ACCESSIBILITY GUIDELINE - ADAAG CONFORMANCE

ELEVATED	ACCESSIBLE	RAMP ACCESSIBLE	GROUND	TYPES
10	7/5	0	6/3	2/3

RH5

FOR KIDS
AGES
5-12

GENERAL NOTES:

This conceptual plan is based on information provided prior to construction. Detailed site information, including the following, should be obtained, evaluated, and utilized in the final project design. Exact site dimensions, topography, existing utilities, soil conditions and drainage solutions.

WARNING: Accessible safety surfacing material is required beneath and around this equipment that has a critical height value (Fall Height) appropriate for the highest accessible part of this equipment. Refer to the CPSC'S Handbook For Public Playground Safety, Section 4: Surfacing.

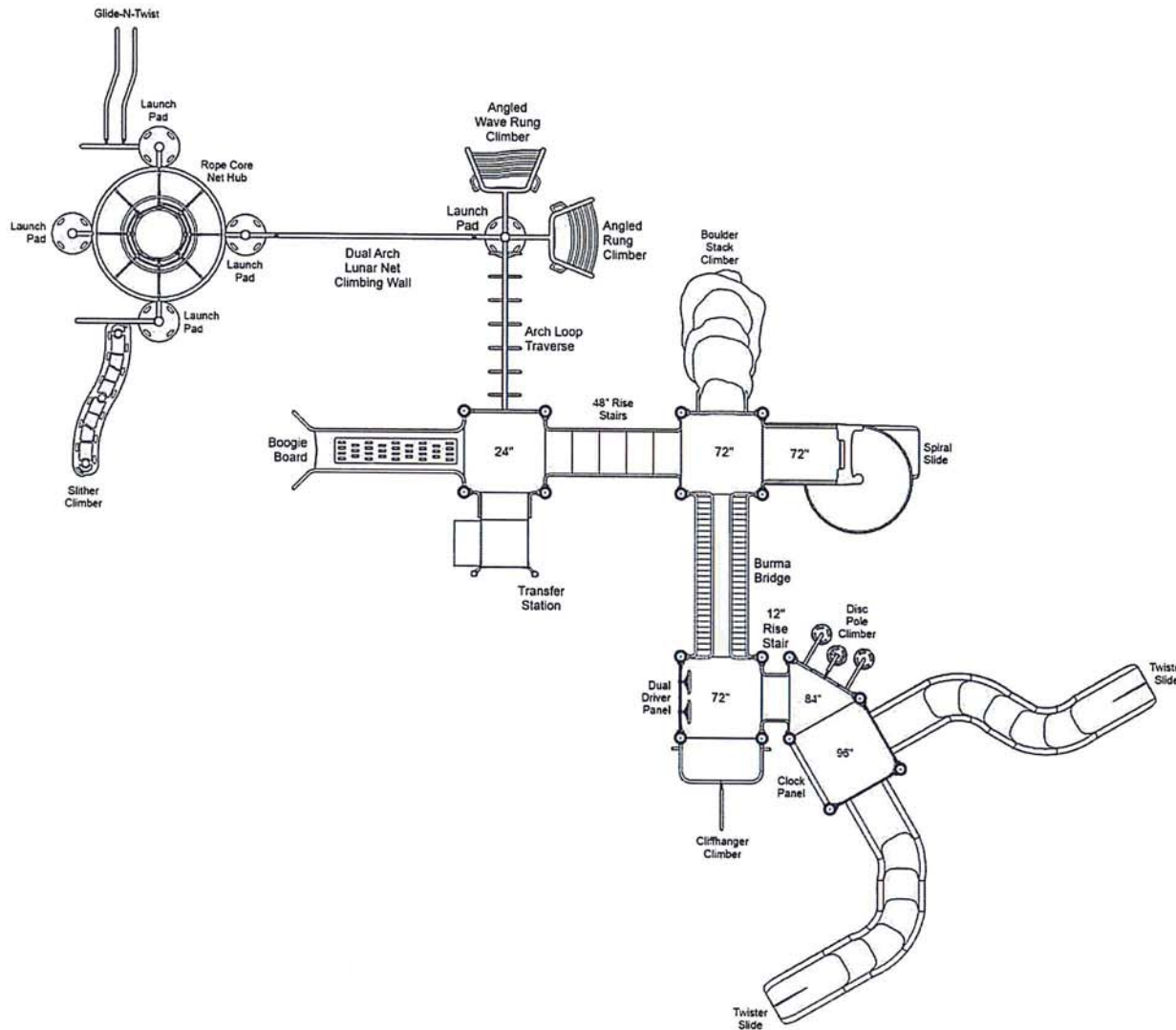

STRUCTURE#: R5H7D47EA

PROJECT#: ZCY16C09E9B-1

DATE: 9/30/2016 | DRAWN BY: KJK

MIN. USE ZONE: 65' x 58'

PLAYCRAFT REP:
Zenon Company



**VICTORIA PARK SOUTH
TOP VIEW**

ADA ACCESSIBILITY GUIDELINE - ADAAG CONFORMANCE

ELEVATED	ACCESSIBLE	RAMP ACCESSIBLE	GROUND	TYPES
2	2/1	0	2/1	2/1

R5 FOR KIDS
AGES
2-5

GENERAL NOTES:
This conceptual plan is based on information provided prior to construction. Detailed site information, including the following, should be obtained, evaluated, and utilized in the final project design. Exact site dimensions, topography, existing utilities, soil conditions and drainage solutions.

WARNING: Accessible safety surfacing material is required beneath and around this equipment that has a critical height value (Fall Height) appropriate for the highest accessible part of this equipment. Refer to the CPSC'S Handbook For Public Playground Safety, Section 4: Surfacing.

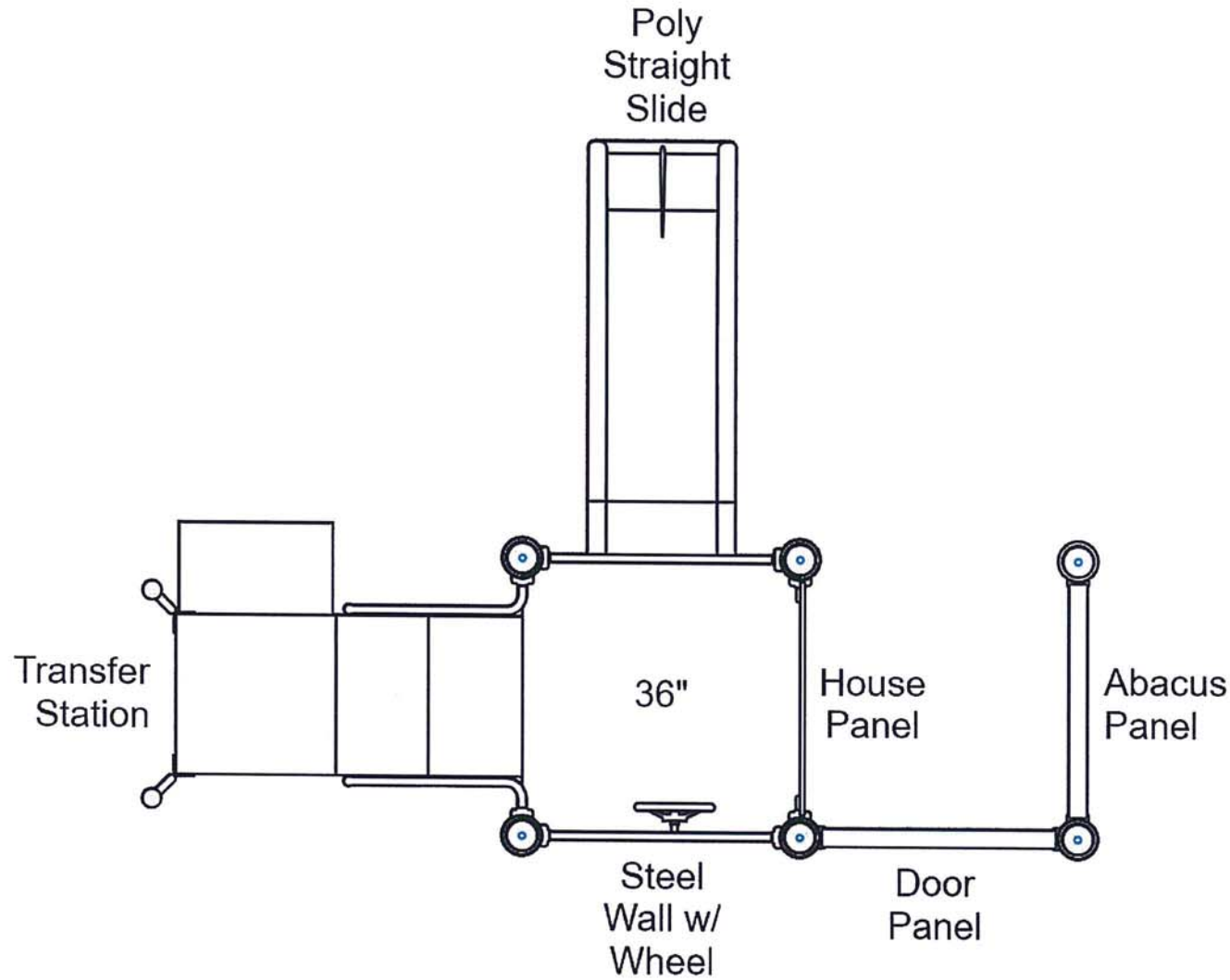

STRUCTURE#: R50CEF45A

PROJECT#: ZCY16C09E9B-1

DATE: 9/30/2016 | DRAWN BY: KJK

MIN. USE ZONE: 22' x 22'

PLAYCRAFT REP:

Zenon Company



VICTORIA PARK SOUTH SITE PLAN

ADA ACCESSIBILITY GUIDELINE - ADAAG CONFORMANCE

ELEVATED	ACCESSIBLE	RAMP ACCESSIBLE	GROUND	TYPES
12	9/6	0	8/4	4/3

R5

FOR KIDS
AGES
[Mixed]

GENERAL NOTES:

This Preliminary Site Plan is based on measurements that were provided in the initial planning phase. All dimensions must be verified prior to the submission of a purchase order. Krauss Craft, Inc. will not be held responsible for any discrepancies between actual dimensions and dimensions submitted in the planning phase.

The Minimum Use Zone for a play structure is based on the product design at the time of proposal. Components and structure designs may be subject to change which may affect dimensions. Therefore, before preparing the site, we strongly recommend obtaining final drawings from the factory (available after the order is placed and included in the Assembly Manual).

WARNING: Accessible safety surfacing material is required beneath and around this equipment that has a critical height value (Fall Height) appropriate for the highest accessible part of this equipment. Refer to the CPSC'S Handbook For Public Playground Safety, Section 4: Surfacing.

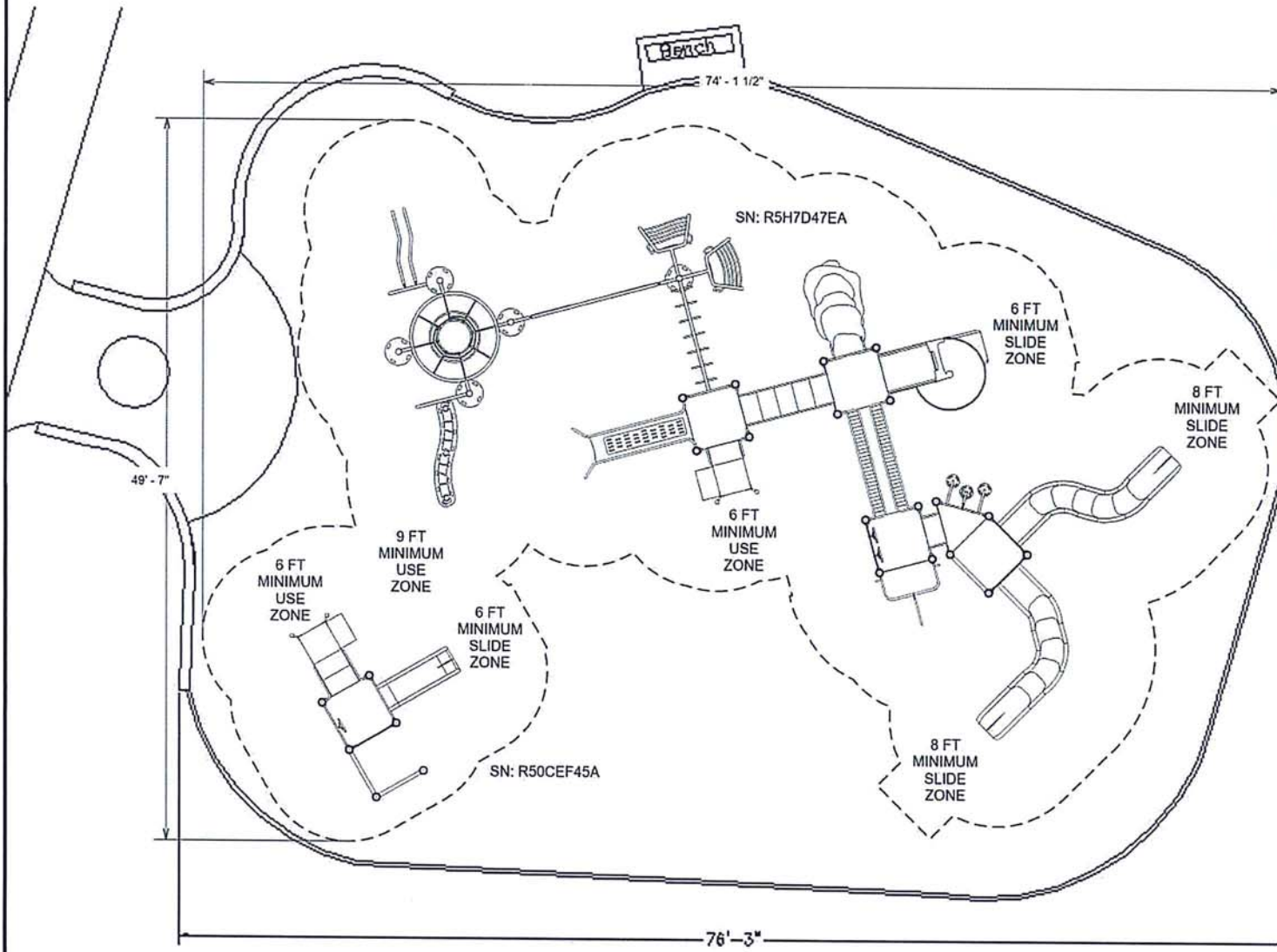

PROJECT#: ZCY16C09E9B-1

DATE: 9/30/2016 | DRAWN BY: KJK

MIN. USE ZONE: 75' x 50'

PLAYCRAFT REP:
Zenon Company



VICTORIA PARK SOUTH
SW VIEW

RH5

FOR KIDS
AGES
5-12

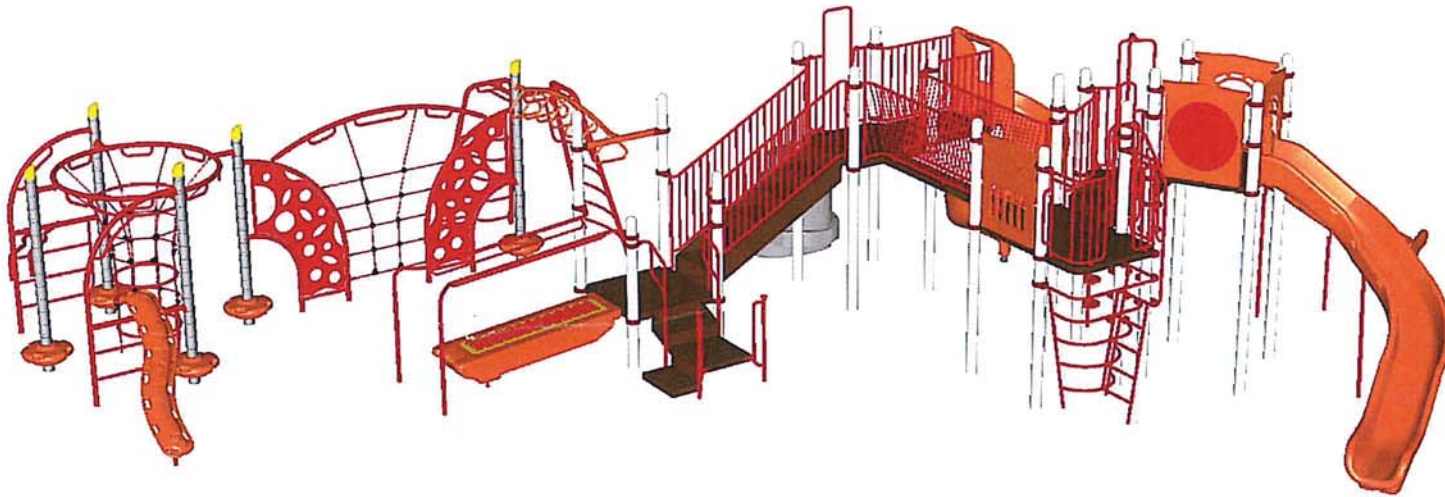

STRUCTURE#: R5H7D47EA

PROJECT#: ZCY16C09E9B-1

DATE: 9/30/2016 | DRAWN BY: KJK



VICTORIA PARK SOUTH
NE VIEW

RH5

FOR KIDS
AGES
5-12



STRUCTURE#: R5H7D47EA

PROJECT#: ZCY16C09E9B-1

DATE: 9/30/2016 | DRAWN BY: KJK



VICTORIA PARK SOUTH
SW VIEW

R5

FOR KIDS
AGES
2-5



STRUCTURE#: R50CEF45A
PROJECT#: ZCY16C09E9B-1
DATE: 9/30/2016 | DRAWN BY: KJK

VICTORIA PARK SOUTH
NE VIEW

R5

FOR KIDS
AGES
2-5



STRUCTURE#: R50CEF45A

PROJECT#: ZCY16C09E9B-1

DATE: 9/30/2016 | DRAWN BY: KJK



COLONY PARK TOP VIEW

ADA ACCESSIBILITY GUIDELINE - ADAAG CONFORMANCE

ELEVATED	ACCESSIBLE	RAMP ACCESSIBLE	GROUND	TYPES
5	5/3	0	2/2	2/2

R5
FOR KIDS
AGES
2-5

GENERAL NOTES:

This conceptual plan is based on information provided prior to construction. Detailed site information, including the following, should be obtained, evaluated, and utilized in the final project design. Exact site dimensions, topography, existing utilities, soil conditions and drainage solutions.

WARNING: Accessible safety surfacing material is required beneath and around this equipment that has a critical height value (Fall Height) appropriate for the highest accessible part of this equipment. Refer to the CPSC'S Handbook For Public Playground Safety, Section 4: Surfacing.

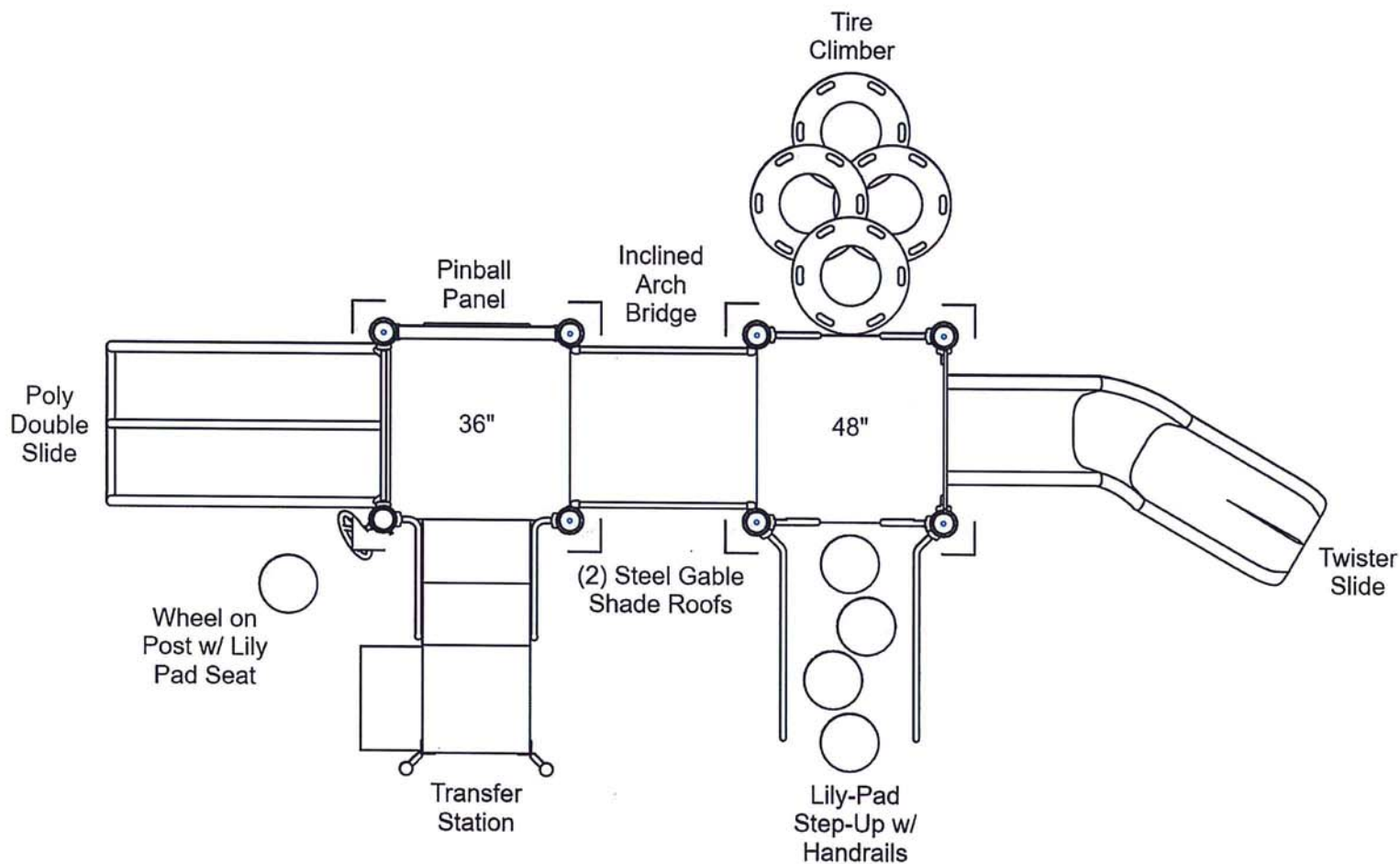

STRUCTURE#: R50D7BD6A

PROJECT#: ZCY16CC3D5A-1

DATE: 9/28/2016 | DRAWN BY: KJK

MIN. USE ZONE: 37' x 27'

PLAYCRAFT REP:

Zenon Company



**COLONY PARK
TOP VIEW**

ADA ACCESSIBILITY GUIDELINE - ADAAG CONFORMANCE

ELEVATED	ACCESSIBLE	RAMP ACCESSIBLE	GROUND	TYPES
0	0/0	0	1/0	1/0

R5 FOR KIDS
AGES
2-5

GENERAL NOTES:

This conceptual plan is based on information provided prior to construction. Detailed site information, including the following, should be obtained, evaluated, and utilized in the final project design. Exact site dimensions, topography, existing utilities, soil conditions and drainage solutions.

WARNING: Accessible safety surfacing material is required beneath and around this equipment that has a critical height value (Fall Height) appropriate for the highest accessible part of this equipment. Refer to the CPSC'S Handbook For Public Playground Safety, Section 4: Surfacing.

PC 1502
Sand Digger
w/ Seat

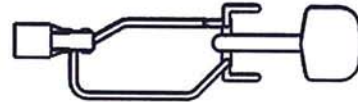

STRUCTURE#: FREPC1502

PROJECT#: ZCY16CC3D5A-1

DATE: 9/28/2016 | DRAWN BY: KJK

MIN. USE ZONE: 6' x 6'

PLAYCRAFT REP:
Zenon Company



COLONY PARK TOP VIEW

ADA ACCESSIBILITY GUIDELINE - ADAAG CONFORMANCE

ELEVATED	ACCESSIBLE	RAMP ACCESSIBLE	GROUND	TYPES
0	0/0	0	1/0	1/0

R5 FOR KIDS
AGES
2-5

GENERAL NOTES:

This conceptual plan is based on information provided prior to construction. Detailed site information, including the following, should be obtained, evaluated, and utilized in the final project design. Exact site dimensions, topography, existing utilities, soil conditions and drainage solutions.

WARNING: Accessible safety surfacing material is required beneath and around this equipment that has a critical height value (Fall Height) appropriate for the highest accessible part of this equipment. Refer to the CPSC'S Handbook For Public Playground Safety, Section 4: Surfacing.

PC 1501
Sand Digger

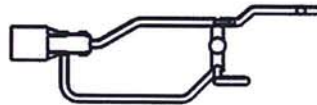

STRUCTURE#: FREPC1501

PROJECT#: ZCY16CC3D5A-1

DATE: 9/28/2016 | DRAWN BY: KJK

MIN. USE ZONE: 6' x 6'

PLAYCRAFT REP:

Zenon Company



COLONY PARK SITE PLAN

ADA ACCESSIBILITY GUIDELINE - ADAAG CONFORMANCE

ELEVATED	ACCESSIBLE	RAMP ACCESSIBLE	GROUND	TYPES
5	5/3	0	4/2	3/2

R5

FOR KIDS
AGES
2-5

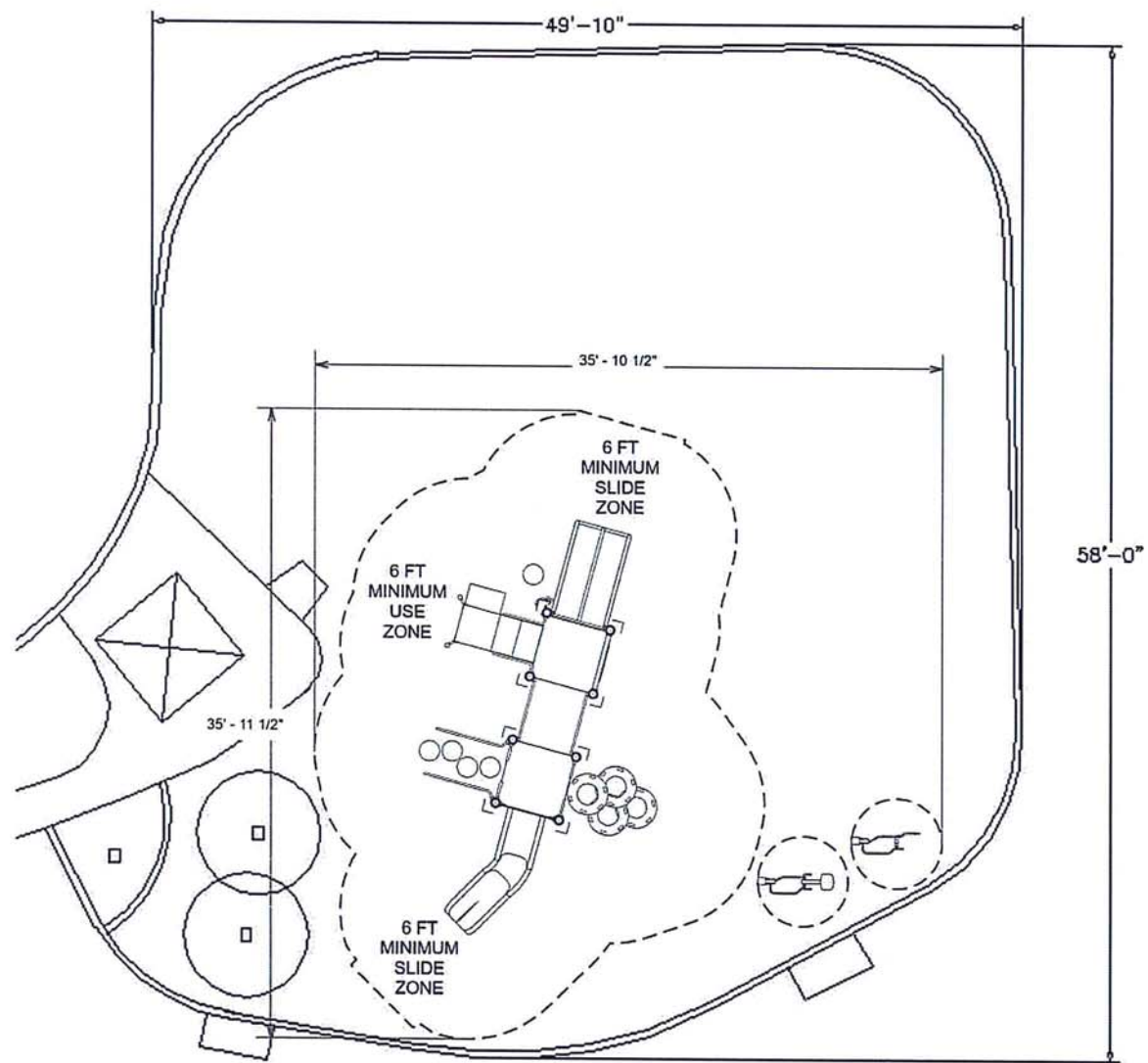

GENERAL NOTES:
This Preliminary Site Plan is based on measurements that were provided in the initial planning phase. All dimensions must be verified prior to the submission of a purchase order. Krauss Craft, Inc. will not be held responsible for any discrepancies between actual dimensions and dimensions submitted in the planning phase.

The Minimum Use Zone for a play structure is based on the product design at the time of proposal. Components and structure designs may be subject to change which may affect dimensions. Therefore, before preparing the site, we strongly recommend obtaining final drawings from the factory (available after the order is placed and included in the Assembly Manual).

WARNING: Accessible safety surfacing material is required beneath and around this equipment that has a critical height value (Fall Height) appropriate for the highest accessible part of this equipment. Refer to the CPSC'S Handbook For Public Playground Safety, Section 4: Surfacing.

PROJECT#: ZCY16CC3D5A-1
DATE: 9/28/2016 | DRAWN BY: KJK

MIN. USE ZONE: 36' x 36'

PLAYCRAFT REP:
Zenon Company



COLONY PARK
SW VIEW

R5

FOR KIDS
AGES
2-5



STRUCTURE#: R50D7BD6A

PROJECT#: ZCY16CC3D5A-1

DATE: 9/28/2016 | DRAWN BY: KJK

COLONY PARK
NE VIEW

R5

FOR KIDS
AGES
2-5



STRUCTURE#: R50D7BD6A
PROJECT#: ZCY16CC3D5A-1
DATE: 9/28/2016 | DRAWN BY: KJK



COLONY PARK
SW VIEW

R5

FOR KIDS
AGES
2-5

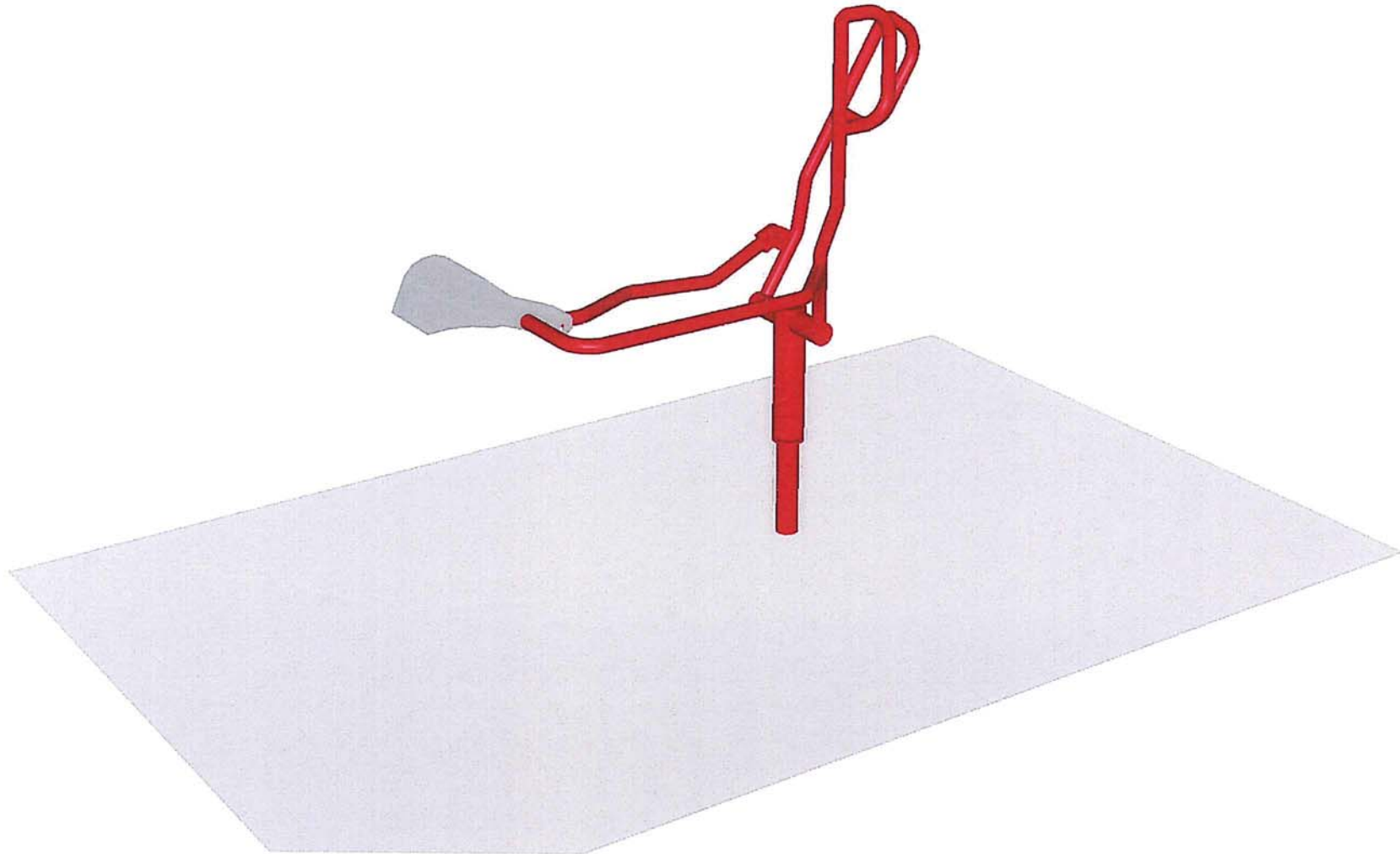

STRUCTURE#: FREPC1501
PROJECT#: ZCY16CC3D5A-1
DATE: 9/28/2016 | DRAWN BY: KJK

